

OK

# THE CITY OF NAPOLEON

BUILDING & ZONING DEPARTMENT

255 W. RIVERVIEW

(419) 592-4010

## Building Permit

Permit Number: BP2008-203

Page 1 of 1

Printed: 12/5/2008

### ADDRESS:

*557 Main St. W.*

### Applicant

Name: S.A. Sidle Construction, Inc  
Address: 13136 St Rt 18

Approval Date: 12/5/2008  
419-264-6850

### Owners

Name: Mr. Larry Sidle  
Address: 665 W Maumee Ave  
Napoleon, OH 43545

Phone: 419-592-8117

### Contractors

Contractor Type: **Builder**

Name: S.A. Sidle Construction, Inc  
Address: 13136 St Rt 18

Holgate, OH 43527

Phone: 419-264-6850

### Fees and Receipts:

Number	Description	Amount
FEE2008-803	Building Permit Fee (Auto)	\$24.00
FEE2008-804	State 1% fee (Calc)	\$0.24
<b>Total Fees:</b>		<b>\$24.24</b>
RCPT2008-472		\$24.24
<b>Total Receipts:</b>		<b>\$24.24</b>

waterproof basement, footer tile

APPLICANTS SIGNATURE: \_\_\_\_\_

DATE: \_\_\_\_\_

REMINDER: YOU MUST CALL (419)592-4010 FOR AN INSPECTION DEC - 5 2008

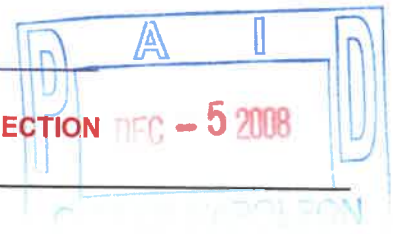

DATE: 12-12-08  
INSTALLED BY: SCOTT SIDLE  
INSPECTED BY: MARTY CROSSLAND

FOOTER TILE

W. MAIN ST.

8" W.M.

555

557

4" PIT. FOLLOWS BASEMENT WALL UNDER GARAGE

24" CORR. DUAL WALL HDPE SUMP PIT

OUTLET ONTO GROUND

4" HDPE 6" FROM WALL TYP.

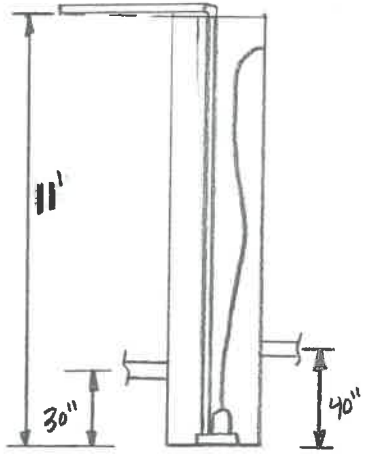

HALEY AVE

15 SAN.

DATE: 12-12-08  
INSTALLED BY: SCOTT SIDLE  
INSPECTED BY: MARTY CROSSLAND

FOOTER TILE

W. MAIN ST.

555

557

4" VIT. FOLLOWS BASEMENT WALL UNDER GARAGE

24" CORR. DUAL WALL HDPE SUMP PIT

OUTLET ONTO GROUND

4" HDPE 6" FROM WALL TYP.

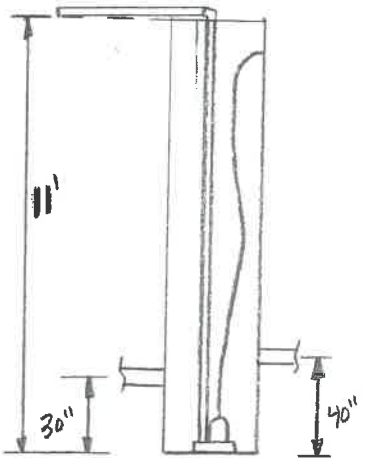

HALEY AVE

10 SAN.

88"

W.M.

